

LM5008 Evaluation Board

National Semiconductor
Application Note 1330
Ravi Murugesappa
May 2004



Introduction

The LM5008 evaluation board is designed to provide the design engineer with a fully functional step down switching regulator to evaluate LM5008 regulator IC, in a typical environment.

The performance of evaluation board is as follows:

- Input range: 12V to 95V, transients upto 100V (**absolute maximum**)
- Output voltage: 10V
- Output current: 300mA
- Measured efficiency: 89% at 200mA and $V_{IN} = 30V$
- Board size: 31.9mm x 44.4mm

Theory of Operation

The LM5008 Step down switching regulator features all of the functions needed to implement low cost, efficient, Buck bias regulators. This high voltage regulator contains an 100V, 0.5A N-channel Buck switch. The regulator is based on hysteretic control scheme using an on-time inversely proportional to input voltage (V_{IN}). This feature allows the operating frequency to remain relatively constant with load and input voltage variations. The hysteretic control requires no control loop compensation, while providing fast load transient response. Additional protection features include : Thermal Shutdown, V_{CC} undervoltage lockout and maximum duty-cycle limiter. LM5008 can be used in numerous applications to efficiently regulate step down higher voltage inputs. This regulator is well suited for 48V telecom and the new 42V automotive power bus ranges.

The LM5008 operates in discontinuous conduction mode at light load currents or continuous conduction mode at heavier load currents. In discontinuous conduction mode, current through the output inductor starts at zero and ramps up to the peak value during the buck switch on time, and then back to zero during buck switch off time. In discontinuous conduction mode, the operating frequency can be relatively low and

will vary with load. Therefore at light loads the conversion efficiency is maintained, since switching losses decrease with reduction in switching frequency.

The evaluation board just needs one high voltage power-supply (upto 100V and current rating of 0.5A). The maximum output power is 3 watts. Either an electronic load or resistor bank can be used for testing evaluation board.

Start-up Feature

There is no soft-start feature in LM5008, and it normally comes up with full load current to supply the power demanded by the load within a short time. The LM5008 contains an intelligent current limit OFF timer intended to reduce the foldback characteristic inherent with fixed off-time over-current protection. If the current in the Buck FET exceeds 550mA the present cycle is immediately terminated (cycle by cycle current limit). Following the termination of the cycle a non-resettable current limit off timer is initiated. The duration of off time is a function of the external setting resistor (R_{cl}) and the FB pin voltage. When FB pin voltage = 0V the current limit off time is internally preset to 35 μ s. This condition occurs in short circuit operation when a maximum amount of off time is required.

In cases of overload (not complete short circuit) the current limit off time can be reduced as a function of the output voltage (measured at the FB pin). Reducing the off time during smaller overloads reduces the amount of foldback and also reduces the initial start-up time.

Low Ripple Configuration

For applications where lower output voltage ripple is required the output load can be connected directly to the low ESR output capacitor, as shown below. The evaluation board is laid out in such a way that, user can use either (high ripple or low ripple) options by simply shifting the output connector. The series resistor (R) will degrade the load regulation however.

Low Ripple Configuration (Continued)

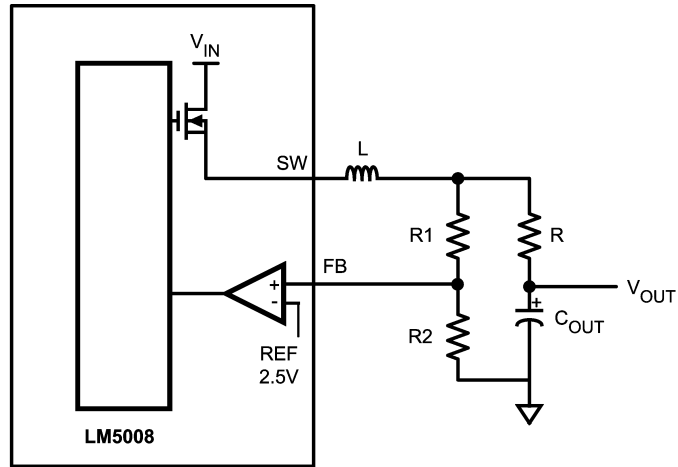

Low Ripple Configuration Output

20105501

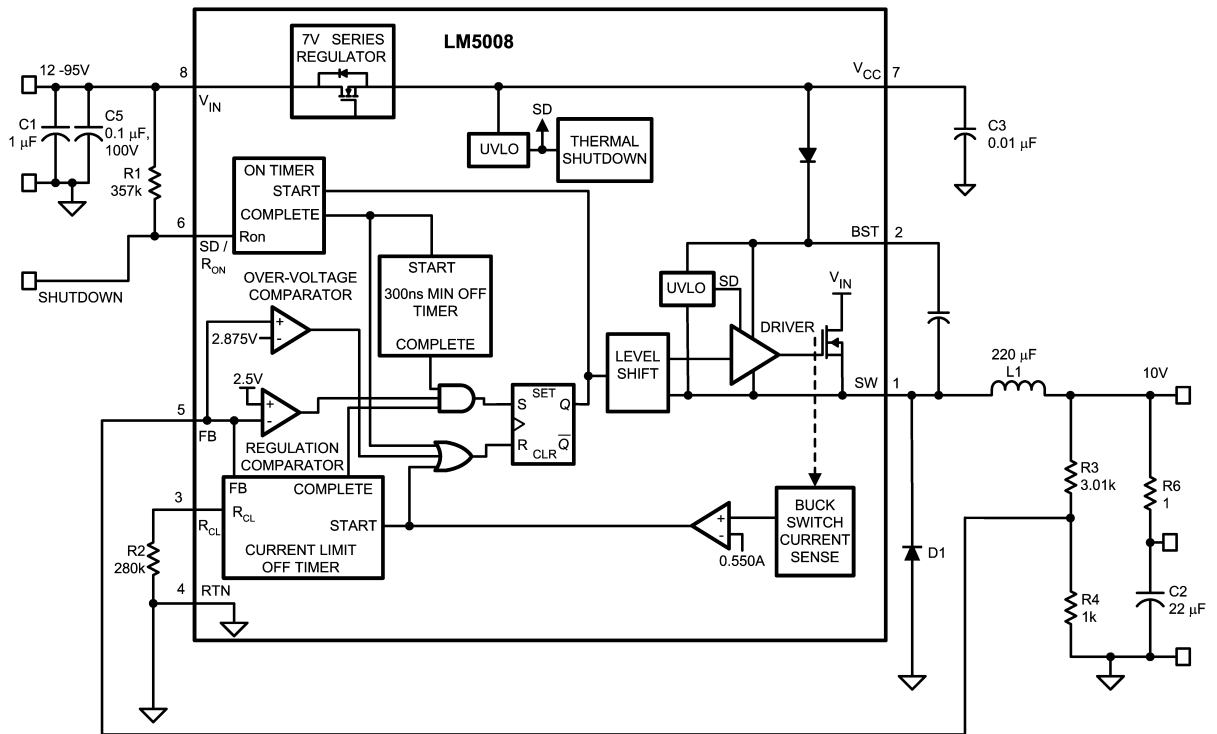

Evaluation Board Schematic Diagram

20105502

Bill of Materials

ITEM		PART NUMBER	DESCRIPTION	VALUE
C	1	C4532X7R2A105M	CAPACITOR, CER, TDK	1 μ , 100V
C	2	C3225X7R1C226M	CAPACITOR, CER, TDK	22 μ , 16V
C	3	C1206C104K5RAC	CAPACITOR, CER, KEMET	0.1 μ , 50V
C	4	C1206C103K5RAC	CAPACITOR, CER, KEMET	0.01 μ , 50V
C	5	C3216X7R2A104KT	CAPACITOR, CER, TDK	0.1 μ , 100V
D	1	MURA110T3	DIODE, 100V, ON SEMI	
L	1	SLF10145T-221MR65-1	BUCK INDUCTOR, TDK	220 μ H
R	1	CRCW12063573F	RESISTOR	357K
R	2	CRCW12062803F	RESISTOR	280K
R	3	CRCW12063011F	RESISTOR	3.01K
R	4	CRCW12061001F	RESISTOR	1K
R	5	CRCW12061R00F	RESISTOR	1
U	1	LM5008	REGULATOR, NATIONAL	

Efficiency Measurements

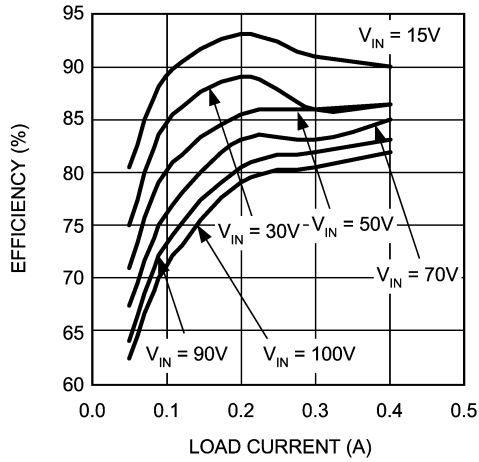

LM5008 Efficiency

20105503

Load Transient

$V_{IN} = 50V, V_{OUT} = 10V, \text{ Load change from } 1k\Omega \text{ to } 20k\Omega$

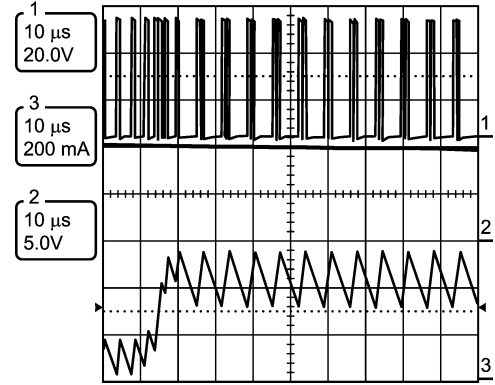

20105506

CH1: Switch Node Voltage

CH2: Output Voltage

CH3: Inductor Current

Start-up Behavior

$V_{IN} = 50V, V_{OUT} = 10V, \text{ Load Resistance} = 30\Omega$

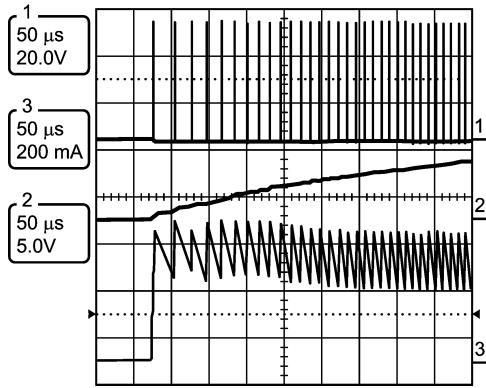

20105504

CH1: Switch Node Voltage

CH2: Output Voltage

CH3: Inductor Current

Load Current vs Switching Frequency

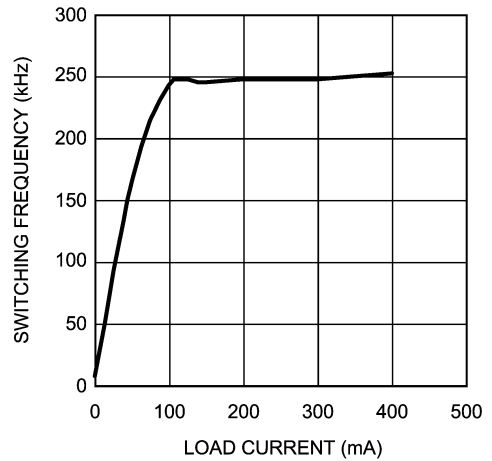

20105507

Normal Operation

$V_{IN} = 50V, V_{OUT} = 10V, \text{ Load Resistance} = 30\Omega$

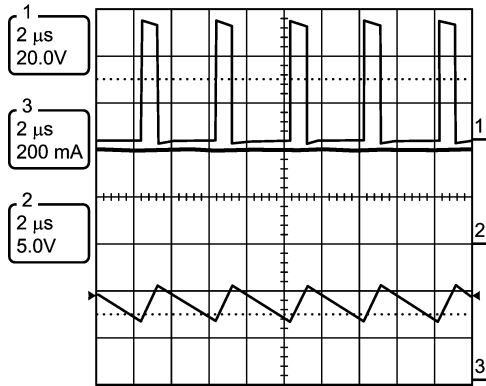

20105505

CH1: Switch Node Voltage

CH2: Output Voltage

CH3: Inductor Current

Input Voltage vs Switching Frequency

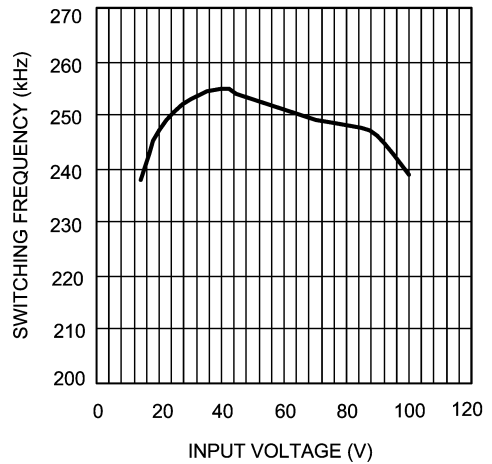

20105508

PCB Layouts

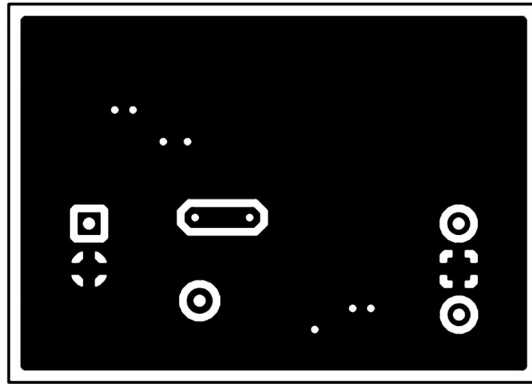

20105513

Top Layer

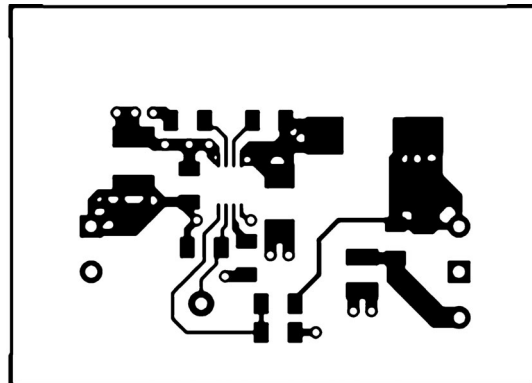

20105514

Silk Screen

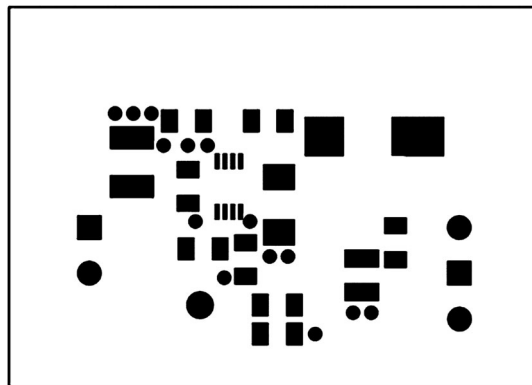

20105515

Bottom Layer

PCB Layouts (Continued)

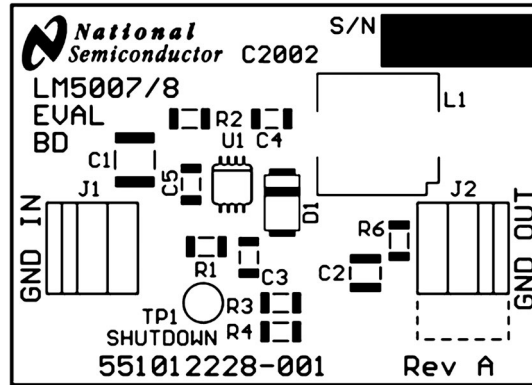

Top Soldermask

20105516

LIFE SUPPORT POLICY

NATIONAL'S PRODUCTS ARE NOT AUTHORIZED FOR USE AS CRITICAL COMPONENTS IN LIFE SUPPORT DEVICES OR SYSTEMS WITHOUT THE EXPRESS WRITTEN APPROVAL OF THE PRESIDENT AND GENERAL COUNSEL OF NATIONAL SEMICONDUCTOR CORPORATION. As used herein:

1. Life support devices or systems are devices or systems which, (a) are intended for surgical implant into the body, or (b) support or sustain life, and whose failure to perform when properly used in accordance with instructions for use provided in the labeling, can be reasonably expected to result in a significant injury to the user.
2. A critical component is any component of a life support device or system whose failure to perform can be reasonably expected to cause the failure of the life support device or system, or to affect its safety or effectiveness.

BANNED SUBSTANCE COMPLIANCE

National Semiconductor certifies that the products and packing materials meet the provisions of the Customer Products Stewardship Specification (CSP-9-111C2) and the Banned Substances and Materials of Interest Specification (CSP-9-111S2) and contain no "Banned Substances" as defined in CSP-9-111S2.



National Semiconductor
Americas Customer
Support Center
Email: new.feedback@nsc.com
Tel: 1-800-272-9959

National Semiconductor
Europe Customer Support Center
Fax: +49 (0) 180-530 85 86
Email: europe.support@nsc.com
Deutsch Tel: +49 (0) 69 9508 6208
English Tel: +44 (0) 870 24 0 2171
Français Tel: +33 (0) 1 41 91 8790

National Semiconductor
Asia Pacific Customer
Support Center
Email: ap.support@nsc.com

National Semiconductor
Japan Customer Support Center
Fax: 81-3-5639-7507
Email: jpn.feedback@nsc.com
Tel: 81-3-5639-7560

www.national.com